

EMI/EMC FILTER

IX SERIES



FEATURES

- Ideally suited for products that must conform to part 15, FCC regulations.
- Metal cased miniature type with high performance.
- Meet over voltage category II of IEC 60664 and comply with IEC 60950.
- Uses IEC connector that meets the safety standards of virtually all certifying organizations.
- Soldering Lug, Faston Tab, PCB mounting type are available.
- Short length and under tab for small space.
- Excellent filtering characteristics for high frequencies.
- Earth coil provided.

APPLICATIONS

- Digital equipments.
- Personal computers and peripherals.
- Measuring instruments.
- For use in miniature equipments.
- For monitors and display units.

SPECIFICATIONS

Model	Rated Voltage (AC,DC)	Rated Current	Leakage Current (250V AC)	Temperature Rise	Operating Temperature
IX-(N)01***	250V	1A	-	30°C max.	-25°C to + 85°C Including temperature rise
IX-(N)02***	250V	2A	-	30°C max.	
IX-(L)03***	250V	3A	-	45°C max.	
IX-(N)03***	250V	3A	-	30°C max.	
IX-(N)06***	250V	6A	-	45°C max.	
IX-(N)L10***	250V	10A	-	45°C max.	
IX-(N)15***	250V	15A	-	45°C max.	
IX-(N)***0-*	-	*	0.01mA max.	-	
IX-(N)***C-*	-	*	0.075mA max.	-	
IX-(N)***D-*	-	*	0.10mA max.	-	
IX-(N)***2-*	-	*	0.35mA max.	-	
IX-(N)***3-*	-	*	0.50mA max.	-	

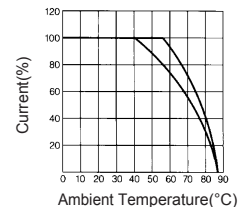

Note :
 Test Voltage:1500V AC one minute line to earth.
 Insulation Resistance:300 Mohm min, at 500V DC.
 Voltage Drop:1V max. at rated current.
 Weight:50g
 Inlet :Compatible with IEC-60320

Model Number Construction

I	X	03	4	2	S
Input Connector I : IEC Connector	Special Design X : Screw and PCB Mounting/ Metal Case (With ground choke)	Current Rating:AC rms 01,N01 : 1amp 02,N02 : 2amp 03,N03,L03 : 3amp 06,N06 : 6amp L10,N10 : 10amp 15,N15 : 15amp (*L*,*N* high performance)	Line-Line Cap. Value 2 : 0.022 μ F 4 : 0.047 μ F A : 0.1 μ F B : 0.15 μ F	Line-Gnd Cap. Value 2 : 2200 pF 3 : 3300 pF C : 330 pF D : 470 pF 0 : None	Output Terminal Style P : PCB Pin S : Solder Lug H : Faston Tab #250

Shapes and Dimensions

* PCB mounting Type

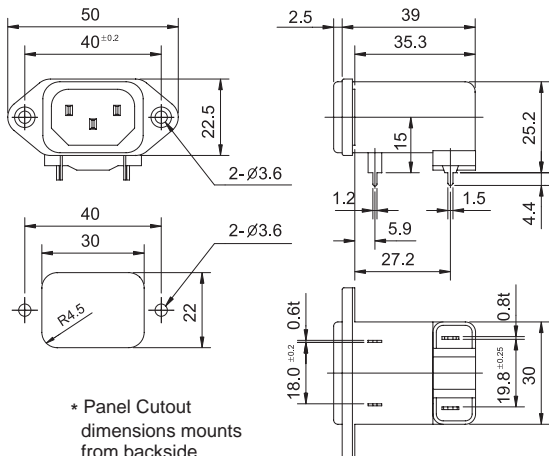

* Panel Cutout dimensions mounts from backside

* Soldering Lug type

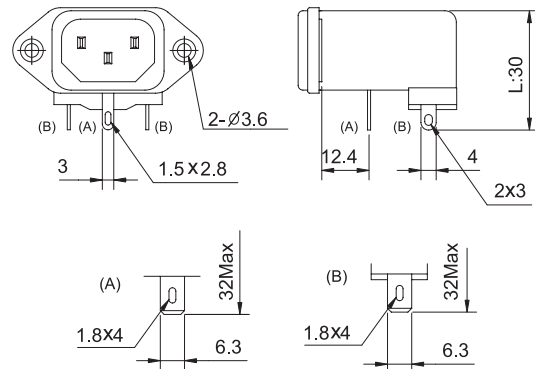

* Faston tab type
* Unit : mm
* General tolerance : ±0.5

Attenuation Characteristics

● Common Mode

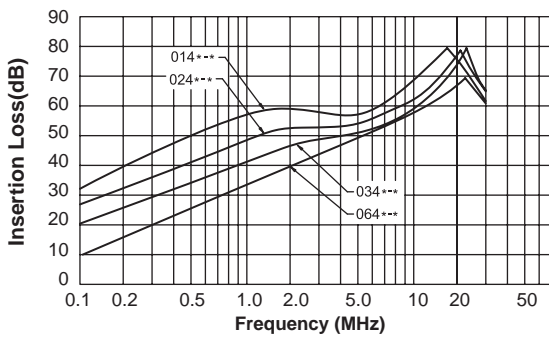

● Differential Mode

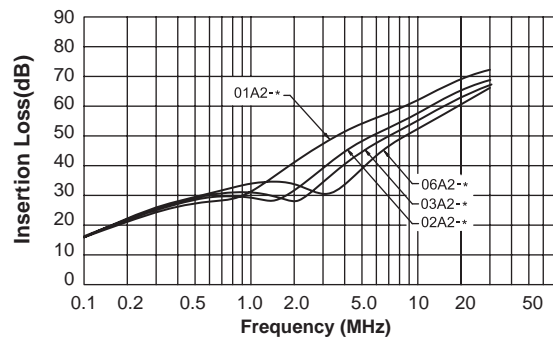

● Common Mode

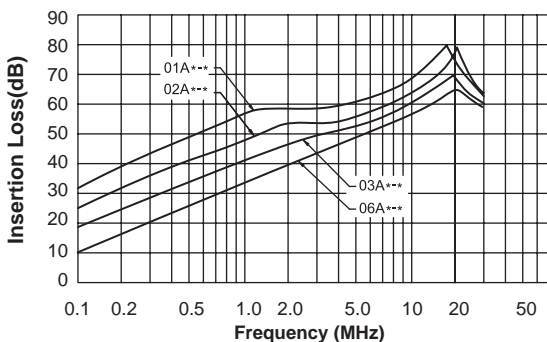

● Differential Mode

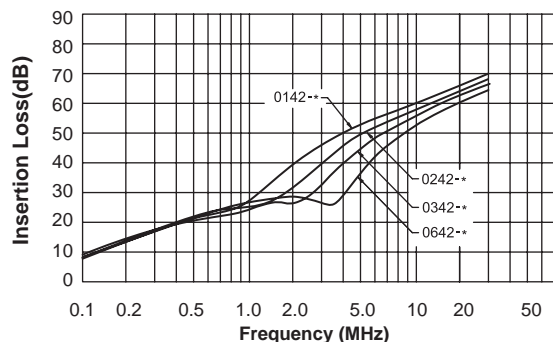

● Circuit Diagram

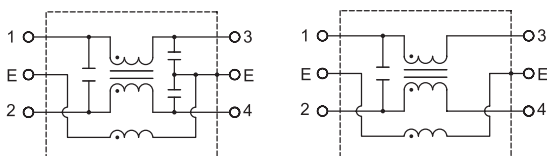

IX-***** type

IX-****0* type

● Measurement configuration

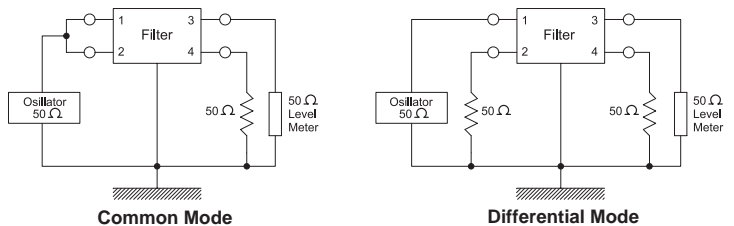

Common Mode

Differential Mode